

CNC自動旋盤用4倍速回転工具

「アイビー・スピンドル」

4 Times Speeder Spindle
for Swiss CNC

「IB・SPINDLE」

株式会社スズキプレシオン

Suzuki Precion Co., Ltd.



4x Speeder Spindle IB • SPINDLE



Dramatically reduce your machining time with these IB•SPINDLE Speeders.

Specification

■ It only takes ONE WRENCH to install on your existing machines.

■ No additional driving unit or transmitter needed.

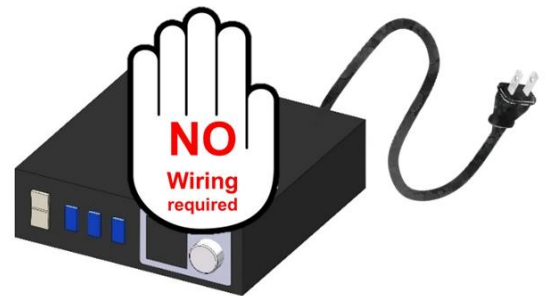
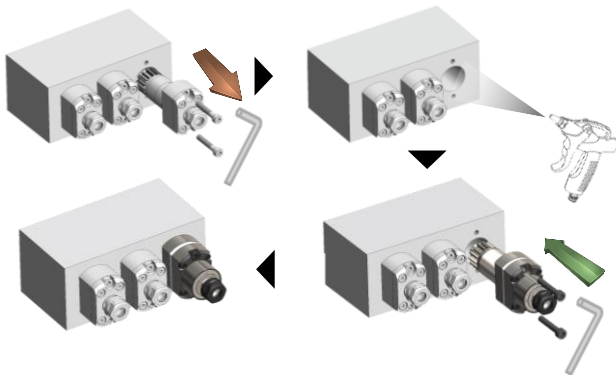

■ Cutting tool overhang is amazingly 20mm shorter than a standard spindle.

■ Please use an ER11 collet chuck.

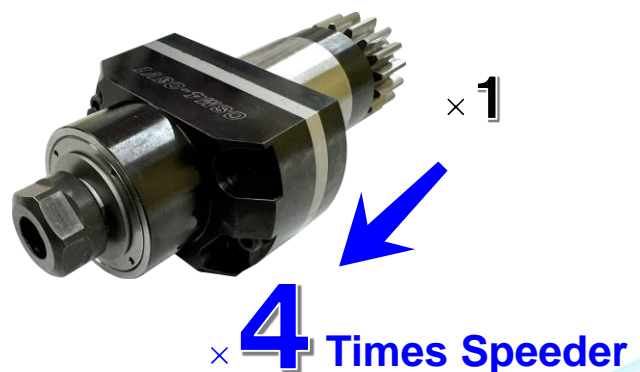
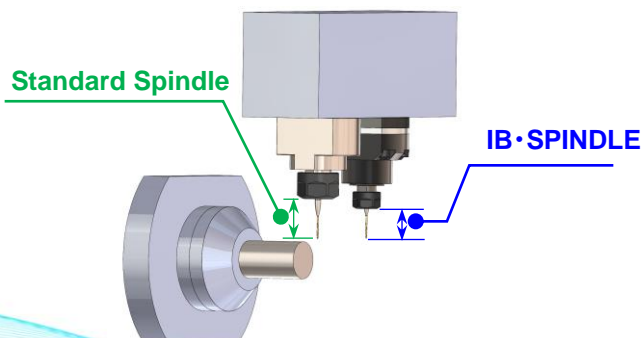

CSM4 - 01

※受注生産品
Made-to-order

L20VII · VIII · IX / L20EVII · IX Evolution
L20X Innovation
M20 / M32V C20 / 32

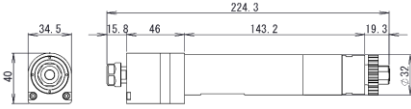

CSM4 - 02V1

L20E-VIII · IX Evolution / L20X Innovation

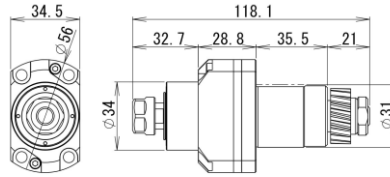

CSM4 - 03V1

A20VII Evolution / A20VII (A20-3F7) / A32VII Evolution
L20XII Innovation / L20VIII · IX · X · XII
L32VIII · IX · X · XII M32III · V · VII · VIII Innovation
D25VII / VIII

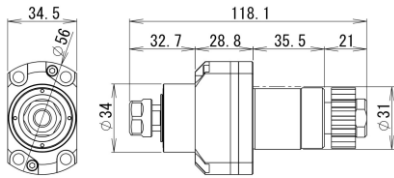

CSM4 - 04V1

L12VII Innovation / L20EVIII · IX Evolution / L20X Innovation
L20XII Innovation / L20VIII · IX · X · XII
M16V · VII · VIII (U153B-Option)
M20 / M32 (Y265274-Option)

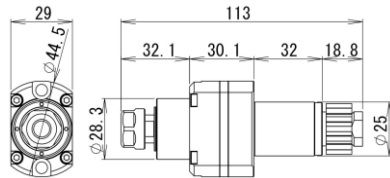

CSM4 - 05V1

L20X · XII Innovation / L20X · XII

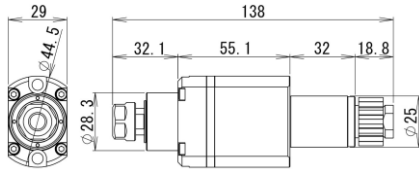

CSM4 - 07V1

MC20

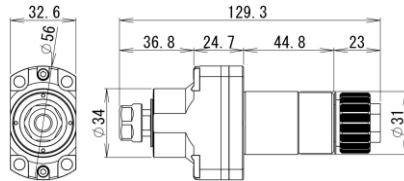

Install Information

- Cincom A20VII Evolution Line
- Cincom A32VII Evolution Line

- Cincom D25 VII · VIII

- Cincom MC20

- ▶ CSM4-03V1
- ▶ CSM4-04V1

- ▶ CSM4-03V1

- ▶ CSM4-07V1

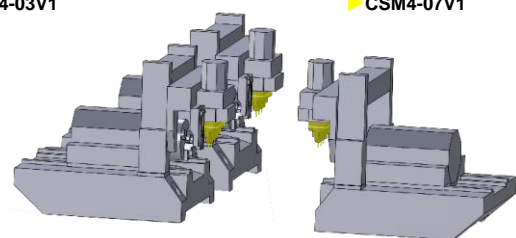
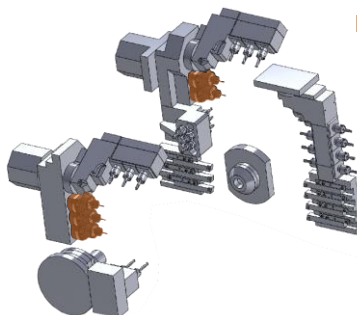
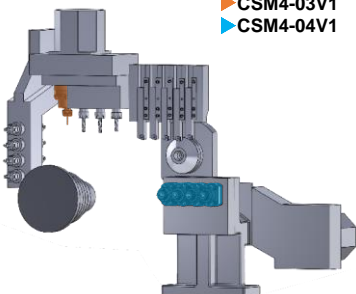

■ Cincom L12Ⅶ Innovation Line

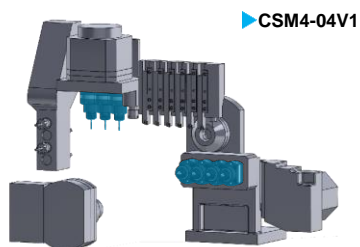

■ Cincom L20

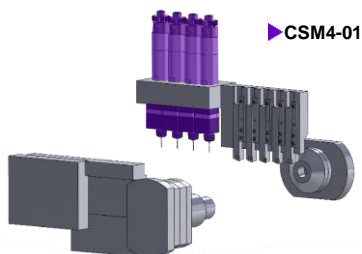

■ Cincom L20EⅧ · IX Evolution Line
■ Cincom L20X Innovation Line

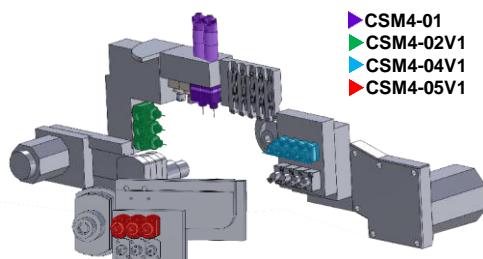

■ Cincom L220Ⅷ · IX · X · XII

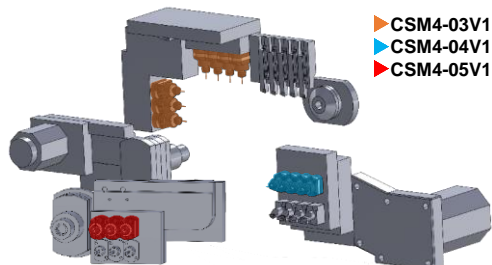

■ Cincom L32Ⅷ · IX · X · XII

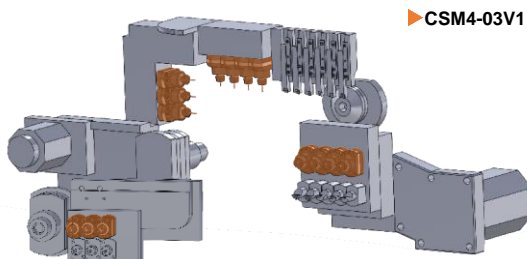

■ Cincom M20Ⅲ · V / M32Ⅲ · V

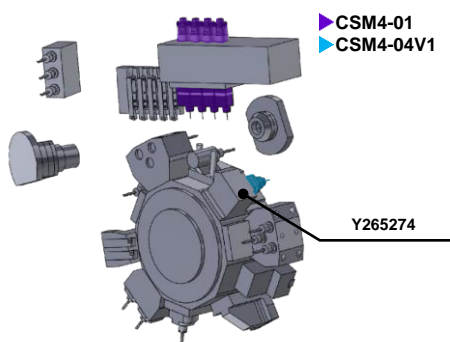

■ Cincom M16V · VII · VIII

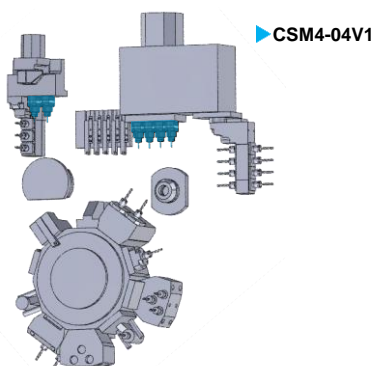

■ Cincom M32V · VII · VIII

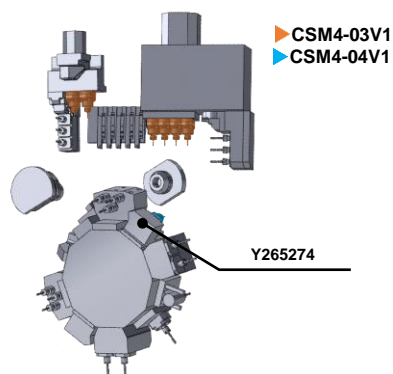

M20/M32 タレットで正面・背面での高速加工を実現。

It enables high-speed machining on both front and back cutting with the M20/M32 turret.

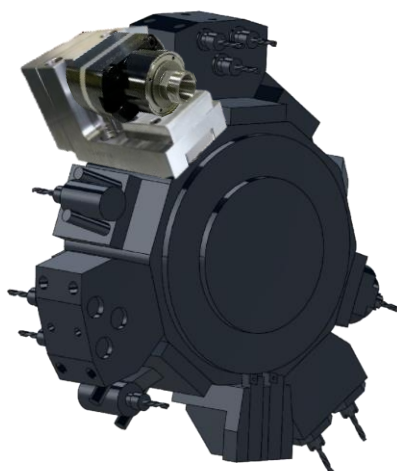
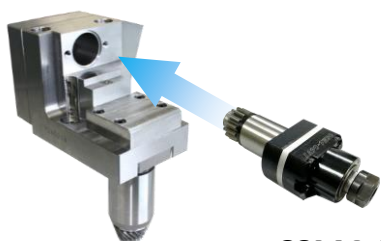

※Y265274はシチズンマシナリー様よりお買い求めください。
Please purchase the holder from Citizen Machinery Ltd.

SSM4 - 01V1

SV12 / SV16 / SV20 / SV38R
SR16 / SR20 / SR20J / SR20RIV / SR32J / SR32J TypeN
SB12R / SB16R / SB20R
SW20 / SP20

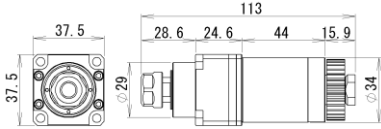

SSM4 - 02V1

SB12R / SB16R / SB20R
SR10J / SR20J / SR16/20R / SR20R II / SR20R III / SR20RIV A/B
SR32J / SR32J TypeN / SR38TypeA/B
SW12R II / ECAS12/20 / SP20

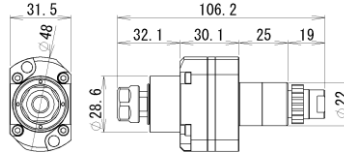

SSM4 - 04V1

SW12R / SW20 / SV20R / SB16/20R
SR20J / SR20RIV / SR38 / SR38J

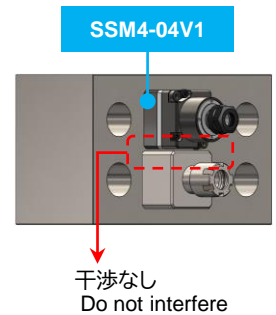
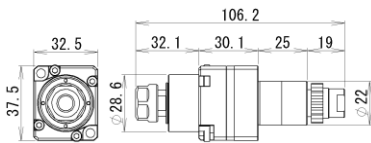

【取付例】 Examples

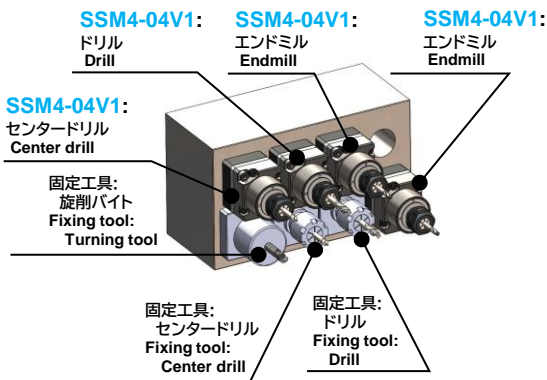

オイルミスト潤滑が可能です。
Oil mist lubrication is possible.

【注意】 Caution

SSM4-02V1とSSM4-04V1はネジサイズが異なります。
The screw sizes of SSM4-02V1 and SSM4-04V1 are different.

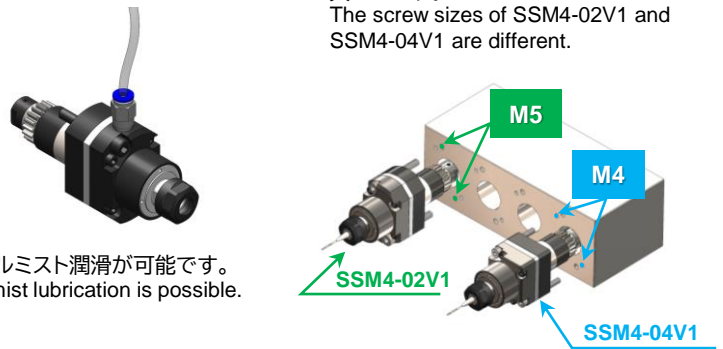

Install Information

■SB12R / 16R / 20R Type E/N/G

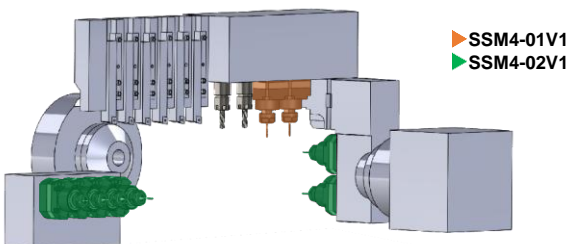

■SB16R / 20R Type C

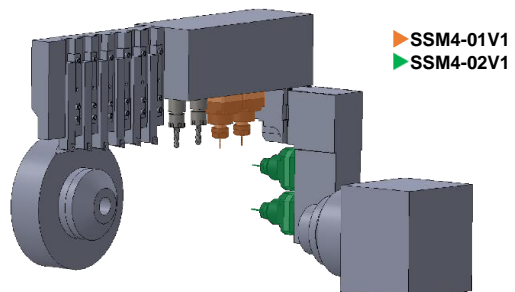

■ SR10J Type C

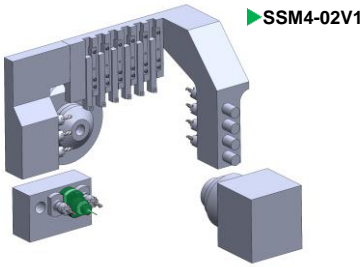

■ SR20J Type C/N

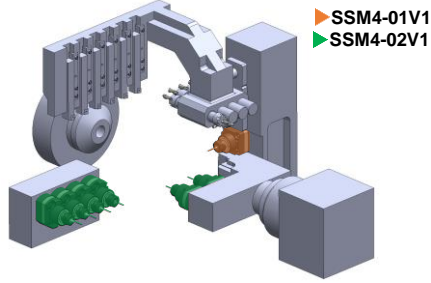

■ SR32J/32J Type N

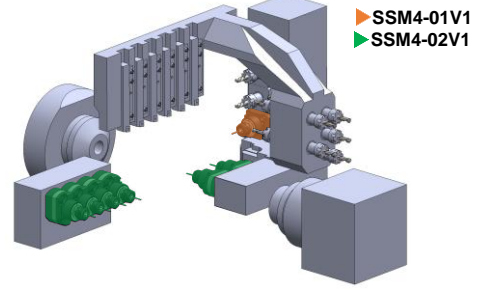

■ SR20RⅣ Type A/B

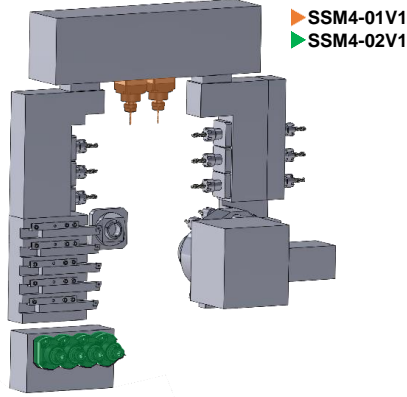
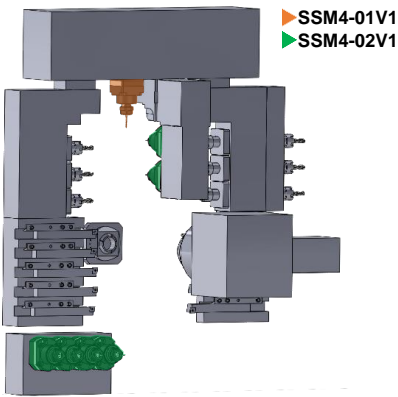

■ SR38 Type A/B

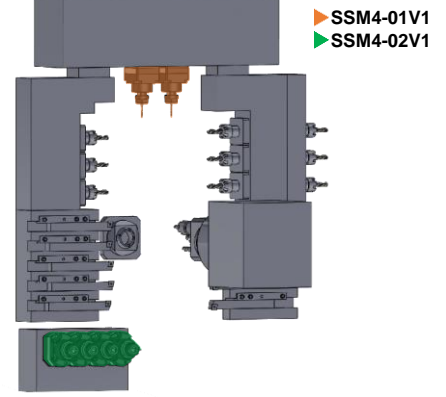

■ SW12R II

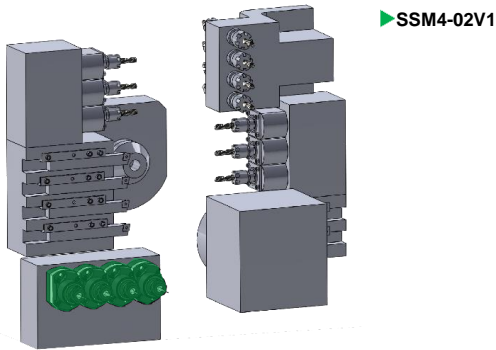

■ SW20

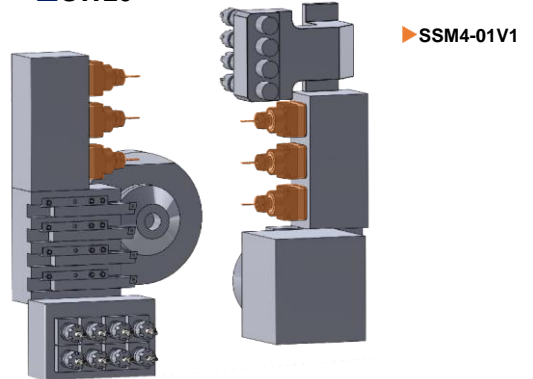

■ SV12/SV20/SV32/SV32J II

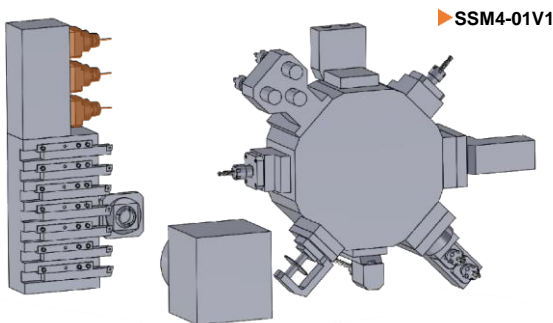

■ SV38R

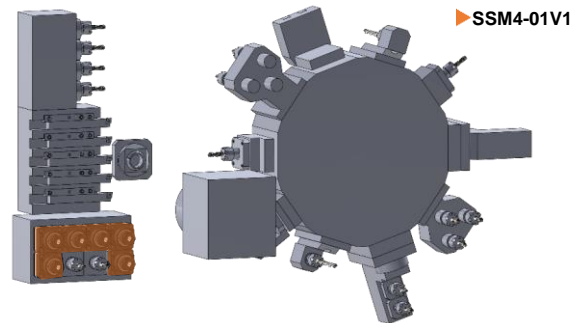

SB,SRの正面・背面での高速加工を実現。

It enables high-speed machining on both front and back cutting with the SB&SR.

※87700156はスター精密様よりお買い求めください。

Please purchase the 87700156 holder from star Micronics Co., Ltd.

87700156

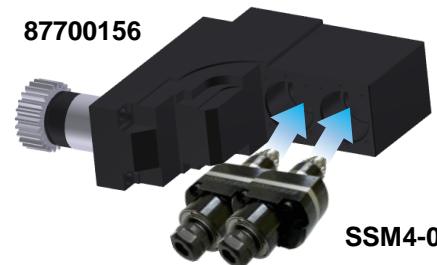

SSM4-02V1

3290-Y671

B0265-II / B0265B-II / B0266-II
B0325-II / B0325B-II / B0326-II

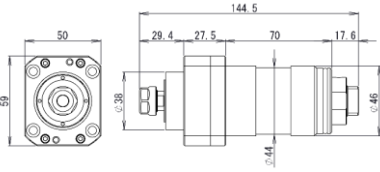

3290-Y681

B0265-II / B0265B-II / B0266-II / B0325-II / B0325B-II
B0326-II / SS267 / SS327 / SS267-5AX / SS327-5AX

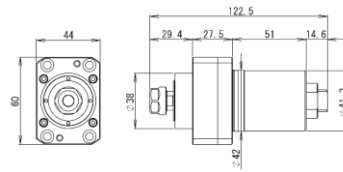

3290-Y3671

B0265-II / B0265B-II / B0266-II
B0325-II / B0325B-II / B0326-II

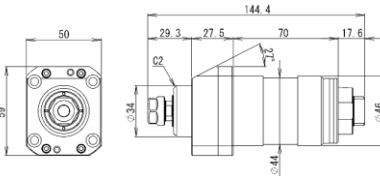

3220-Y7551-0101

B073-III / B0123-III / B0203-III / B074-III / B0124-III / B0204-III
B075-III / B0125-III / B0205-III / B0126-III / B0206-III
P013 / P014 / P033 / P034 / S205 / S206

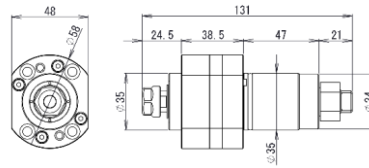

3281-Z06231-0101

S205A / S205 / S206

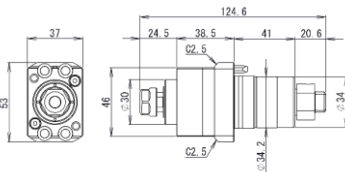

Install Information

■ SS267 / SS327
SS267-5AX
SS327-5AX

■ B0265 II / B0265B-II
B0325-II / B0325B-II
B0266-II / 0326-II

■ S205A / S205 / S206

■ B073-III / B074-III
B075-III / B0123-III
B0124-III / B0125-III
B0126-III / B0203-III
B0204-III / B0205-III
B0206-III

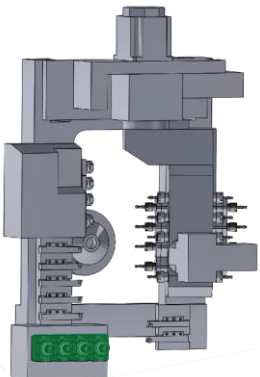

▶ 3290-Y681

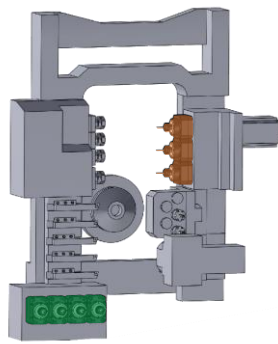

▶ 3290-Y681
▶ 3290-Y671

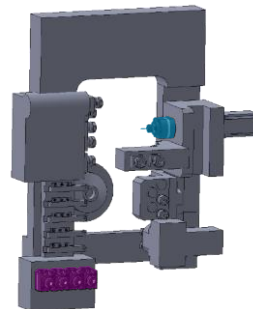

▶ 3281-Z06231-0100
▶ 3220-Y7551-0101

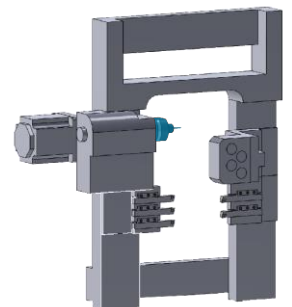

▶ 3220-Y7551-0101

IB·SPINDLE = SDGs

IB·SPINDLE reduces cutting time and contributes to the achievement of SDGs.

What's IB·SPINDLE ?



4Times Speeder

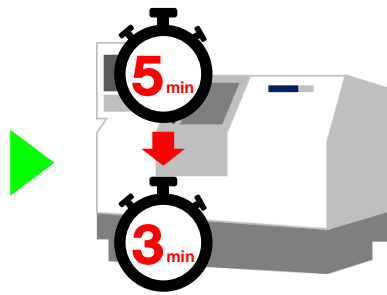

Reduced cutting time



Reduced power consumption

Example

	Standard spindle	IB·SPINDLE
Machining time (min)	5	3
Pieces per hour	12	20
Pieces per day	264	440
Order quantity	10,000pcs	
Processing days	38	23

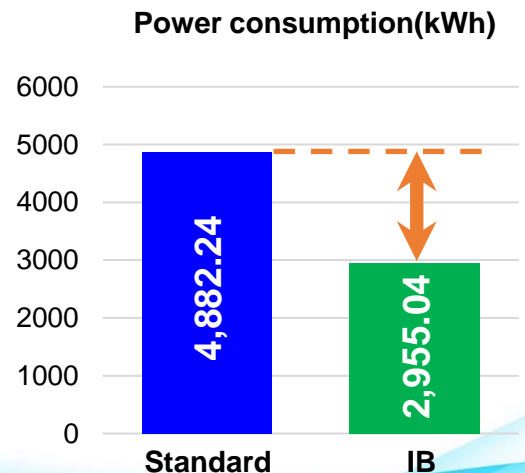

※Daily operating time is calculated as 22 hours.
 ※Rated power consumption is calculated at 7.3kVA.
 ※Power factor is calculated at 0.8.

Contributing to the reduction of electricity bills.

株式会社スズキプレシオン
<https://precion.co.jp>

〒322-0251
栃木県鹿沼市野尻113番地2
TEL 0289-65-6001
FAX 0289-62-8084

【お問い合わせ】
<https://www.precion.co.jp/contact/>



Suzuki Precion Co., Ltd.
<https://www.precion.co.jp/english/>

113-2, Nojiri, Kanuma City, Tochigi
322-0251 Japan
TEL (81)289-65-6001
FAX (81)289-62-8084

【Contact us】
<https://www.precion.co.jp/english/#contact-form>



製品は予告なく、改良のため仕様を変更することがございます。
予めご了承ください。

We reserve the right to make modifications without notice to improve
the performance of our products.